



Design and Implementation of Color Objects Sorting Robotics System Based on Programmable Technique

MeghaMandhare , Faiga sayyed, Ranjit Sonawale, Ajinkya Nikam, Rajat Vadagave, Nikhil Keskar.

UG Student, Department of Electronics and TeleCommunication Technology, Satara College Of Engineering and Management Limb Satara

ABSTRACT

I have design and developed a robotic system comprises of colour object detection and sorting them accordingly. The three colours objects viz. Red, Green and Blue, are identified by the sensor. The robotics arm based on three motors is used to separate them. The TCS230 programmable module based on light to frequency converter technology is used to detect different coloured objects. This type of self-intelligent robotics system which performs all the activity automatically by its own as system is supplied with required power. These types of robotics system are now most widely used in different industrial work where automated and self intelligence is highly recommended.

1 INTRODUCTION

Modern day's invention required a perfect combination of both Electronics and Mechanics, i.e., collectively known as Mechatronics. Mechatronics plays a vital role in rapid growth of modern technology. Not only commercial products are improved by the Mechatronics system, but the field of robotic has also been highly influences. Due to the introduction of modern Mechatronics system the controlling and modification of robotic circuits becomes very convenient. In this paper we tried to provide a brief knowledge about a simple robotic architecture having powerful programmable platform. We have designed a self-intelligent robotic structure capable of detecting and sorting items according to its colour. The initial operation of detecting the colour is done by the colour detecting sensor TCS230, this sensor sense colour with the help of an array 8×8 array of photodiode. The TCS230 colour sensor working principle can be divided on two blocks, array block and current to frequency converter block. The array block helps in detecting the colour and the current to frequency converter block converts the sinusoidal sensor output into square wave, the square wave so converted is then applied to the Arduino microcontroller board, the Arduino so programmed that the robotic arm will accept or reject the item according to its colour, we have tested for only two colour Green and Red, if it is green the item will be accepted and if it is red it will be rejected. The sorting of this items on the basic of their colour is done by the movement of the robotic arm, consisting of two servo dc motor capable of moving 360°. The robot is so designed that it can be used in automated item sorting mechanism in some of the robotic industries where precise and self-intelligent robots are required [1-4].

2 Experimental Setup

The complete system block diagram of the colour sorting robotic arm is shown in Figure 1. The robotic arm is designed with very basic robotics components. The most important element of the robotic arm is the three dc motors, connected one above another. The two motors acts as a two joints of the arms making it capable of moving 360°. The above motor is used to provide the vertical movement of the arm and the middle and the lower motors are used to provide a rotational movement. Basically there are three dc motors in the robotic arm, but for the sorting of the red and green led we have just programmed only one motor ie, the lower most motor.

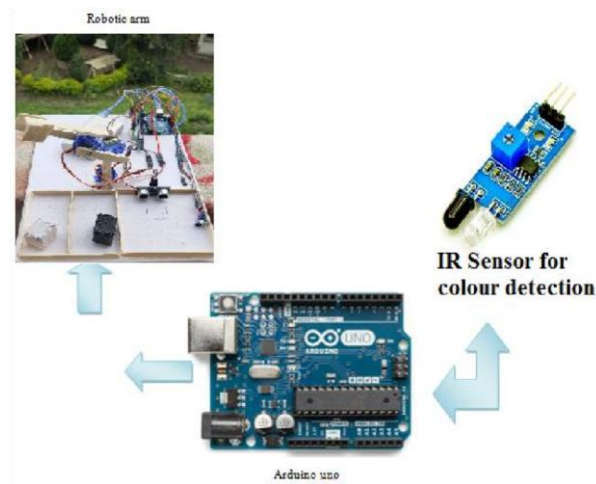

Fig.1: Block diagram of the system

I. Hardware Design

The hardware components of the system are described below:-

- Arduino UNO:** Arduino is an open-source prototyping platform based on easy-to-use hardware and software. Arduino boards are able to read inputs - light on a sensor, a finger on a button, or a Twitter message - and turn it into an output - activating a motor, turning on an LED, publishing something online. You can tell your board what to do by sending a set of instructions to the microcontroller on the board. To do so you use the Arduino programming language (based on Wiring), and the Arduino Software (IDE), based on Processing. Over the years Arduino has been the brain of thousands of projects, from everyday objects to complex scientific instruments. A worldwide community of makers - students, hobbyists, artists, programmers, and professionals - has gathered around this open-source platform their contributions have added up to an incredible amount of accessible knowledge that can be of great help to novices and experts' alike. The Arduino Uno is a microcontroller board based on the ATmega328. It has 14 digital input/output pins (of which 6 can be used as PWM outputs), 6 analog inputs, a 16 MHz crystal oscillator, a USB connector, a power jack, an ICSP header, and a reset button. It contains everything needed to support the microcontroller; simply connect it to a computer with a USB cable or power it with an AC-to-DC adapter or battery to get started. The Uno differs from all preceding boards in that it does not use the FTDI USB-to-serial driver chip. Instead, it features the Atmega8U2 programmed as a USB-to-serial converter. "Uno" means one in Italian and is named to mark the upcoming release of Arduino 1.0. The Uno and version 1.0 will be the reference versions of Arduino, moving forward. The Uno is the latest in a series of USB Arduino boards [5].

Complete circuit diagram of the system is shown below:

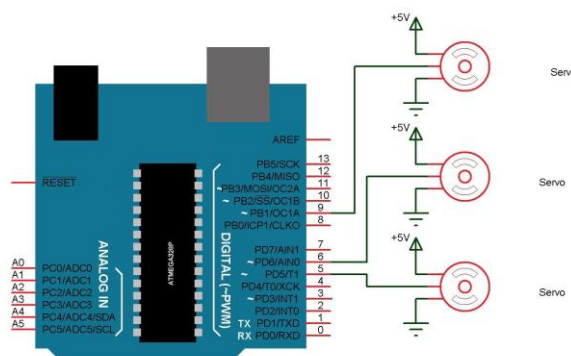

Fig.3: Complete Circuit diagram of the system

II. Software Module

The Arduino Integrated Development Environment- or Arduino Software (IDE)- contains a text editor for writing code, The Arduino Integrated Development Environment - or Arduino Software (IDE) - contains a text editor for writing code, a message area, a text console, a toolbar with buttons for common functions and a series of menus. It connects to the Arduino and Genuino hardware to upload programs and communicate with them. Programs written using Arduino Software (IDE) are called sketches. These sketches are written in the text editor and are saved with the file extension .ino. The editor has features for cutting/pasting and for searching/replacing text. The message area gives feedback while saving and exporting and also displays errors. The console displays text output by the Arduino Software (IDE), including complete error messages and other information. The bottom right-hand corner of the window displays the configured board and serial port. The toolbar buttons allow you to verify and upload programs, create, open, and save sketches, and open the serial monitor [4]. The flowchart of the programme is shown in Fig.4.

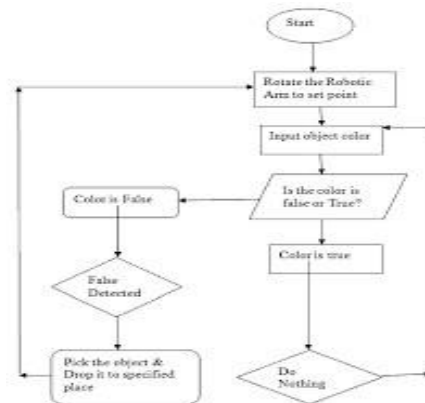

Fig.4: Flowchart of the programme

3. Working Principle

The working of the robotic arm can be broadly classified into two main sections, the first section consists of sensing and detecting of the colour and the second section perform the sorting of items by the robotic arm according to its colour sensed. We have programmed the TCS230 sensor for only for two colors i.e., red and green. First the item is placed above the expose area of the sensor; the sensor senses the colour light with the help of an 8x8 array of photodiodes. Then using a current to frequency converter the reading from the photodiodes is converted into a square wave with a frequency directly proportional to the light intensity. Finally the square wave generated by the sensor is applied to the Arduino UNO microcontroller. Now the sorting of the items are done with the help of robotic arm, here the arm is consist of three dc motors. The motors are driven by the motor driver IC L293D. The Arduino is so programmed that if green colour is sensed then the robot will placed the green item to the green bucket by moving antilock wise direction for 1sec and return back to its initial position again if it red colour is detected then the item will be placed in the red bucket by moving clock wise direction for 1sec and back to its initial position and if it is any other colour is detected the robot will show no action.

4. Results and Discussions

The designed robotic arm is capable of detecting three colours i.e. black, and white .



Fig.5: Snapshot of the Robotic arm in operation

5. Conclusion

The tested system is highly stable and performs the task accurately. The developed system can be widely implemented in Industrial as well as Research for colour specific sorting.

References

- [1] International Journal on Recent and Innovation Trends in Computing and Communication ISSN: 2321-8169, Volume: 4 Issue: 4 483 – 486, Object Sorting using Color Sensor and Arduino.pdf, Dec 12, 2016
- [2] http://midas.herts.ac.uk/helpsheets/arduino_uno.pdf, july 24, 2016
- [3] Vishnu R. Kale1, V. A. Kulkarni, "OBJECT SORTING SYSTEM USING ROBOTIC ARM". Vol. 2, Issue 7, Dec 10, 2016
- [4] International Journal of Scientific Engineering and Research (IJSER), www.ijser.in, ISSN (Online): 2347 - 3878, Volume 2 Issue 7, July 2014
- [5] Arduino Software IDE available to download at website